

Computer Modeling Wind Turbine Blades with Optimal Parameter

<https://doi.org/10.31713/MCIT.2023.006>

Kyryl Degtyariov

A. Pidhornyi Institute for Mechanical Engineering
Problems NAS of Ukraine
Kharkiv, Ukraine
kdegt89@gmail.com

Elena Strelnikova

A. Pidhornyi Institute of Mechanical Engineering
Problems NAS of Ukraine
Kharkiv, Ukraine
elena15@gmx.com

Olena Sierikova

Applied Mechanics and Environmental Technologies Department
National University of Civil Defence of Ukraine
Kharkiv, Ukraine
sierikova_olena@ukr.net

Abstract—The objective of this paper is to develop effective methods of weight optimization for wind turbine blades. New mathematical model based on the application of boundary element method is proposed. Hypersingular integral equations are used to determine the dynamic pressure on the blade. A new version of the nonlinear programming method, based on the usage of adaptive management of optimization procedures, is elaborated. As computer simulation results, the wind turbine blade is obtained with minimal weight.

Keywords—wind turbine blades; hypersingular integral equation; nonlinear programming; weight optimization.

I. INTRODUCTION AND LITERATURE REVIEW

Modern wind power plants are technical complexes consisting of a large number of interacting nodes and aggregates of various purposes. Among them, the main place is occupied by the vane system of the windmill. Optimal design of this type structures uses search procedures for determining the optimal set of parameters that satisfy the specified constraints and provide the best value of the accepted optimal criterion. Such procedures are well known [1], however, they have different effectiveness depending on changing conditions of the search process of the optimum, and it is not always possible, applying any of them separately, to achieve success in acceptable time. The proposed research uses an original hybrid optimization method. With its implementation, the multi-parameter problems of nonlinear programming are effectively solved, taking into account the system limit and functional restrictions [2].

Now a lot of methods are developed to estimate dynamic and strength characteristics of small wind turbines [3, 4]. Both for large and small turbine optimal designing, two types of computational techniques, namely, dynamic and strength analysis, and nonlinear programming are usually involved. For stress-strain analysis the finite [5] and boundary [6] element methods, finite volume methods [7], as well as

computational dynamics methods [8, 9] are effectively applied. The modern aspects of nonlinear programming are described in [10]. It should be noted that the numerical implementation of finite element and volume methods including turbulence models require essential computer time. It leads to difficulties when applying optimization procedures, that require a lot of an objective function and restrictions calculations.

So, in this paper two effective numerical techniques are used. First of them is hypersingular integral method with boundary elements implementation [11] for obtaining the blade dynamic characteristics, and second one is related to nonlinear programming [12]. Coupling these methods allows to elaborate new effective technique for optimal designing blades of wind turbine.

II. METHODOLOGY

A. Problem Statement

To calculate the stress-strain state, the blade is modeled as a thin-walled naturally twisted rod of variable cross-section of length L , fixed to the wind turbine wheel [13]. Let us choose a coordinate system in which Z_G is the axis of rotation, X_G coincides with the axis of the wind wheel, Fig. 1. The Y_G direction is chosen so that the global coordinate system is right-handed. For stress-strain analysis of the blade, introduce a coordinate system (x, y, z) , with axes parallel to X_G, Y_G, Z_G , respectively, is introduced. The origin of coordinates is located at the section center of gravity. The blade geometry is represented by a set of sections. In each of them the following profile parameters are specified: coordinates (x, y) of the external contour, section thickness $h(z)$

It is assumed that the blade is subjected to aerodynamic loads and centrifugal forces. The calculated aerodynamic load is reduced to distributed lateral loads q_x, q_y and distributed torque m_z . As an example, the blade with following characteristics is considered. The blade length including the extension is

$L = 19.13$ m. The elastic constants are taken as follows: modulus of elasticity of the extension $E_0 = 2 \cdot 10^5$ MPa, the elasticity modulus of the blade E varied from $4.92 \cdot 10^4$ up to $2.5 \cdot 10^4$ MPa; Poisson's ratio is $\nu = 0.18$, material density is $\rho = 1.6 \cdot 10^3$ kg/m³.

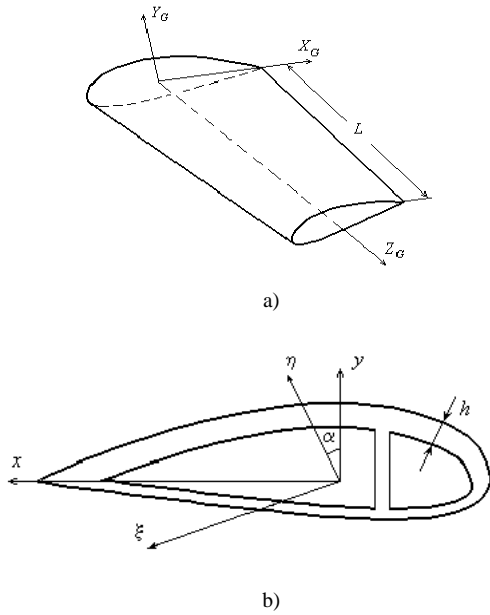

Figure 1. Blade model a) and its section b)

The speed of windmill rotation is $\Omega = 55$ rpm, the wind speed is 10 m/s. The number of blade sections is assumed to be equal to 65. The thickness in the blade sections varied in the root section at the edge from 5 to 2 mm, the thickness in the section of the extension cord is equal to 8 mm. The displacements and stresses distributions in the blades under of aerodynamic and centrifugal loads are estimated [13]. The stress distributions across the blade section and along z-axis are shown in Fig. 2a), b).

The air environment is assumed to be ideal, incompressible and vortex free. The problem of flow distribution around the blade can be reduced to solving a hypersingular integral equation. It allows us to determine the pressure fall along the blade. Aeroelasticity problem is solved in uncoupled formulation, i.e. deformations and displacements are considered to have any effect on the aerodynamic forces acting on the blade.

For optimal design of such structures, it is necessary to use procedures for minimizing (maximizing) some objective function by appropriately choosing project parameters under given restrictions. The restrictions themselves are functions of the initial parameters too.

Describe a possible formulation of the optimization problem for the wind wheel blade. It is required to find the blade of minimum weight under the following conditions. At stationary aerodynamic loads and centrifugal forces, normal displacement w should not exceed a given value $[w]$, stresses are restricted by the value $[\sigma]$, the first frequency of natural vibrations ω also has to be limited. Thus, for $i=1, \dots, N$ there are

$$|\max w^i| \leq [w], |\max \sigma^i| \leq [\sigma], [\omega_1] \leq \omega \leq [\omega_2]. \quad (1)$$

The objective function here is the blade mass $m = \rho V$, where ρ is the material density, V is the blade volume defined as

$$V = \sum_{i=1}^{N-1} \int_{z_i}^{z_{i+1}} S(z) dz, \quad (2)$$

where $S(z)$ is the cross-sectional area, $(N-1)$ is sections number.

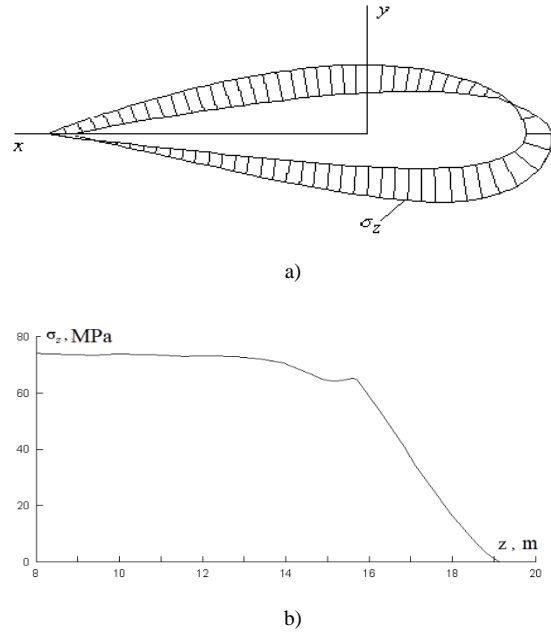

Figure 2. Stress distribution

The variable parameters here are the thickness of the blade in different sections $h_i(z)$, $i = 1, \dots, N$.

Thus, the considered extremal problem (1) (2) is a nonlinear programming problem [2],[10] when it is necessary to find the vector

$$X^* = \arg \operatorname{extr}_{X \in G} F(X) \quad (3)$$

$$F(X) = \rho \zeta$$

in the domain

$$G = \{X: G_i(X) \geq 0, i = \overline{1, m}\} \neq \emptyset \quad (4)$$

of the finite-dimensional parametric space E_n , delivering the extremum of the given objective function $F(X)$, defined in some extension of $H \supset G$.

B. Hypersingular Integral Equation Technique

To calculate aerodynamic loads, the blade is modeled by a bearing surface of finite dimensions S_1 . On this surface there is a vortex layer descending from the trailing edge in the form of a sheet of vortices S_2 , propagating in the direction \mathbf{V}_0 of the oncoming flow. In this case, the pressure drop ΔP across the blades is determined from the Cauchy-Lagrange integral, which in this case has the form

$$\frac{\Delta P}{\rho_0} = -(\operatorname{grad} \Gamma \cdot \mathbf{V}_R), \quad (5)$$

where ρ_0 is the liquid density, Γ is the velocity circulation, and \mathbf{V}_R is the relative fluid velocity, $\mathbf{V}_R = \mathbf{V}_0 - \Omega \times \mathbf{r}$, \mathbf{r} is radius-vector of the point under consideration.

Consider the problem of flowing the ideal incompressible fluid around the thin load-bearing surface. Since the flow is considered irrotational everywhere outside the bearing surface S_1 and the vortex wake S_2 behind it, there exist a potential for the absolute fluid velocity, which satisfies the Laplace equation everywhere outside the discontinuity surfaces S_1 and S_2 . Require that the non-flow condition be satisfied on the bearing surface S_1 , as well the absence of pressure drop along the vortex wake S_2 . In addition, it is necessary to satisfy the condition of attenuation of perturbed velocities at infinity. The most acceptable solution representation to the described above problem for the Laplace equation is the double layer potential [14].

Aerodynamic loads are determined by solving the hypersingular integral equations using the boundary element method as described in [11]. The problem is reduced to solving the following hypersingular equation

$$\frac{1}{4\pi} \iint_S \Gamma(\mathbf{y}) \frac{\partial^2}{\partial n_x \partial n_y} \left(\frac{1}{|\mathbf{x}-\mathbf{y}|} \right) dS_y = g(\mathbf{x}), g(\mathbf{x}) = (\mathbf{V}_0 \cdot \mathbf{n}(\mathbf{x}))$$

Hypersingular integral equation (6) is solved by reducing to the following system of linear algebraic equations [11]

$$\sum_{k=1}^N H_{kj} \Gamma_k = g(\mathbf{x}_{0j}), j = 1, 2, \dots, N,$$

where elements of the matrix H_{kj} are obtained by calculating the hypersingular integrals over boundary elements [14].

Note that over most blade part the stresses σ_z are almost constant, Fig. 2b). This result is obtained due to the variability of the cross-section parameters along the blade length.

C. Hybrid Optimization Method with Adaptive Control

For optimal design of complex multi-parameter objects of the type under consideration, it is convenient to use automatic hybrid search optimization method [1], applied to find the local optimal vector X^* of the conditional extremum problem, modeling, in particular, problem (1) – (4).

The analysis of optimization procedures and features of solving the optimal design problems shows that the simple accumulation of effective methods in the software library and even the introduction of an interactive solution mode, cannot provide the effective conditions for optimization. This is due to the fact that the task being implemented is not provided in advance with an appropriate set of attributes by which the control metaprogram would be able to identify the situation and assign the necessary method.

The essence of the proposed method is as follows. There are a number of hybrid methods that make up the hybrid coalition $\{M_i\}$. The criterion $Q(\sigma)$ is set, which determines during the process, which of the hybrids in given situation σ can be used to achieve the goal most effectively.

A control function $u = u(Q(\sigma))$ is introduced, which establishes an adaptive strategy for putting into operation a specific hybrid $M_k \in \{M_i\}$, $i = 1, \dots, k, \dots, s$ (or a group of methods-hybrids). The joint actions of

methods-hybrids ensure a more effective achievement of the goal than each of the hybrids of the coalition individually. This is achieved by introducing special adaptive control, which obtains vectors of minimizing sequences $\{X_{kr}\}$, search directions $\text{Dir } X_{kr}$, and search adaptive steps h_{kr} , in accordance with the changing situation σ .

In general, adaptive control u can be represented as

$$\left\{ \begin{array}{l} X_k^r \\ \text{Dir } X_k^r \\ h_k^r \end{array} \right\} = \sum_{i=1}^s u_i(Q(\sigma_k)) \left\{ \begin{array}{l} X_k^{M_i} \\ \text{Dir } X_k^{M_i} \\ h_{ki} \end{array} \right\},$$

$$\sum_{i=1}^s u_i(Q(\sigma_k)) = 1, \quad (8)$$

where $u_i(Q(\sigma_k))$ are non-negative control functions defined on the set $\{\sigma_k\}$ of situations, X_k^r , $\text{Dir } X_k^r$, h_k^r are the point, the direction emanating from this point, and the adapting search step generated by M_i method from the coalition $\{M_i\}$, respectively, k is an iteration number. The following modifications of methods were selected as hybrids M_i for this version of the hybrid optimization method: adaptive step-by-step descent, Abramov scheme, ravine modification, Hooke-Jeeves, Davidon-Fletcher-Powell methods, parallel tangent method, secant motion along the boundary of region G [10].

(7) On each of the selected search directions, one-dimensional minimization of the objective function was carried out [12]. In [2] it is shown that the hybrid method can solve a wide class of problems much more efficiently than each of the abovementioned hybrids.

III. RESULTS AND DISCUSSION

To obtain an optimal design, the wind turbine blade with the following parameters was considered: $L = 4$ m, elastic modulus $E = 5 \cdot 10^5$ MPa, Poisson's ratio $\nu = 0.3$, material density $\rho = 1.6 \cdot 10^3$ kg/m³, wind wheel rotation speed $\Omega = 20$ rpm, wind speed 10m/s, $[\sigma] = 200$ MPa, frequency range $[\omega_1] = 0.1$ Hz, $[\omega_2] = 10$ Hz. The blade width varied from 1 m to 0.6 m.

In the process of solving the problem, the fields of displacements and stresses in the blade under aerodynamic loads are determined. The number of sections was taken equal to 28.

The maximum displacement in the plane of rotation of the wind wheel, normal to the OZ axis, is 28.5 cm, maximum bending stresses in the root section of the blade is 12.8 MPa, first frequency of natural oscillations is equal to 2.28 Hz. Table 1 shows the results of solving the optimization problem for the series blade sections Z_i . The initial values of thickness in sections h_0 and optimal parameters h^* are presented. In the initial version, the mass of the blade was equal to 19.38 kg.

As a result of optimization, the blade with weight equals to 16.64kg was obtained. The only active restriction was the blade movement. The natural frequency of oscillations was changed slightly during the counting process, this change did not violate the specified restrictions. Thus, methods for calculating aerodynamic loads and analyzing the stress-strain state of the wind turbine blades showed high efficiency and accuracy, which made it possible to formulate and solve optimization problem that requires repeated verification calculations. Using the developed in-house hybrid

adaptive method, the problem of weight optimization of wind turbine blades was solved.

TABLE I. INITIAL AND OPTIMAL PARAMETERS OF THE BLADE

Section Number	Coordinates and Thickness		
	Coordinate z, m	Initial Thickness, mm	Optimal Thickness, mm
1	0.800	6.0	5.04
2	1.236	5.6	4.73
3	1.818	5.0	4.21
4	2.400	4.4	3.67
5	2.836	4.0	3.25
6	3.564	3.2	2.41
7	4.000	3.0	2.19

IV. CONCLUSION AND FURTHER RESEARCH

An effective method for weight optimization of wind turbine blades has been developed.

The mathematical model has been developed to determine the air pressure on the wind turbine blade based on the method of hypersingular integral equations and namely the boundary element method for its numerical implementation. The unknown densities are supposed to be constants along the elements. The adaptive hybrid method of nonlinear programming is applied for solving the problem of weight blade optimization.

In this research the new version of the method for solving nonlinear programming problems has been developed, based on the use of a combination of various optimization methods, which are included in the process by introducing the adaptive control. The estimation of the blade of wind power plants was carried out, which allowed reduce its weight while meeting design and strength constraints.

The further research in the area will be concern with application of new innovative composite as materials for wind turbine blades producing [15]. It allows to design the blades of wind turbine with improved mechanical characteristics. The proposed approach will be also generalized to strength and dynamical analysis of wind turbines with a vertical axis of rotation [16] as well as their weight optimization.

ACKNOWLEDGMENT

The authors are very grateful to our foreign collaborators, professors Alexander Cheng, Wessex Institute of Technology, and Jure Ravnik, Head of transport phenomena in fluid and solids laboratory, Maribor University for their continued support and cooperation.

REFERENCES

- [1] N. Smetankina, O. Semenets, A. Merkulova, D. Merkulov, and S. Misura, "Two-Stage Optimization of Laminated Composite Elements with Minimal Mass," in *Smart Technologies in Urban Engineering*, O. Arsenyeva, T. Romanova, M. Sukhonos and Y., Tsegelynyk, Eds. Lecture Notes in Networks and Systems, vol. 536, Cham: Springer, 2023, pp. 456–465. https://doi.org/10.1007/978-3-031-20141-7_42
- [2] V.I. Makeev, E.A. Strel'nikova, P.E. Trofimenko, et al. "Selecting Design Parameters for Flying Vehicles," *Int Appl Mech*, vol. 49, 2013, pp. 588–596. <https://doi.org/10.1007/s10778-013-0592-8>
- [3] L. Battisti, E. Benini, A. Brighenti, S. Dell'Anna, and M.R. Castelli, "Small wind turbine effectiveness in the urban environment," *Renew Energy*, vol. 129, 2018, pp. 102–113. <https://doi.org/10.1016/j.renene.2018.05.062/>
- [4] O. Sierikova, E. Strelnikova, and K. Degtyariv, "Numerical Simulation of Strength and Aerodynamic Characteristics of Small Wind Turbine Blades," in *Integrated Computer Technologies in Mechanical Engineering – 2022*, M. Nechyporuk, V. Pavlikov and D. Kritskiy, Eds. Lecture Notes in Networks and Systems, vol. 657, Cham: Springer, 2018, pp. 357–370. https://doi.org/10.1007/978-3-031-36201-9_31.
- [5] L. Kolodiazhna, and Y.Bykov, "Aeroelastic Characteristics of Rotor Blades of Last Stage of a Powerful Steam Turbine," *J. of Mech. Eng.*, vol. 26(1), 2023, pp. 6–14. <https://doi.org/10.15407/pmach2023.01.006>
- [6] Q. Zang, J. Liu, L. Lu, and L. Gao, "Boundary element analysis of liquid sloshing characteristics in axisymmetric tanks with various porous baffles," *Applied Ocean Research*, vol. 93, 2019, 101963. <https://doi.org/10.1016/j.apor.2019.101963>.
- [7] A. Rusanov, A. Shubenko, O. Senetskyi, O. Babenko, and R. Rusanov, "Heating modes and design optimization of cogeneration steam turbines of powerful units of combined heat and power plant," *Energetika*, vol. 65(1), 2019, pp. 39–50. DOI.org/10.6001/energetika.v65i1.3974
- [8] S.N.A. Yusof, Y. Asako, N.A.C. Sidik, S.B. Mohamed, W. Mohd, A.A. Japar, "A short review on RANS turbulence models," *CFD Letters*, vol. 12(11), 2020, pp. 83–96. 10.37934/cfdl.12.11.8396
- [9] D. Mastrodicasa, E. Di Lorenzo, S. Manzato, and P. Guillaume, "Full-field modal analysis by using digital image correlation technique," *Rotating Machinery, Optical Methods & Scanning LDV Methods*, vol. 6, 2022, pp. 119–130. 10.1007/978-3-030-76335-0_10
- [10] A.E. Sameh, "Nonlinear Modeling, Analysis and Simulation of Wind Turbine Control System With and Without Pitch Control as in Industry," *Advanced Control and Optimization Paradigms for Wind Energy Systems*, Singapore: Springer, 2019, pp. 1–40. DOI: 10.1007/978-981-13-5995-8_1.
- [11] A. Karaiev, and E. Strelnikova, "Singular integrals in axisymmetric problems of elastostatics," *International Journal of Modeling, Simulation, and Scientific Computing*, vol. 11(1), 2020, 2050003. DOI:10.1142/S1793962320500038.
- [12] G. Sheludko, and S. Ugrimov, "The localization method of extremum point for unimodal function", *Journal of Mechanical Engineering* Vol. 19, no. 1, pp. 43–54, 2016, DOI: 10.15407/pmach2016.01.044.
- [13] R. Rzadkowski, V. Gnesin, and L. Kolodyazhnaya, "Aeroelasticity Analysis of Unsteady Rotor Blade Forces and Displacements in LP Last Stage Steam Turbine with Various Pressure Distributions the Stage Exit," *J. Vib. Eng. Technol*, vol. 6, 2018, pp. 333–337. <https://doi.org/10.1007/s42417-018-0049-9>
- [14] V. Gnitko, A. Karaiev, K. Degtyariv, I. Vierushkin and E. Strelnikova, "Singular and hypersingular integral equations in fluid–structure interaction analysis," *WIT Transactions on Engineering Sciences*, vol. 134, 2022, pp. 67–79. DOI:10.2495/BE450061.
- [15] O. Sierikova, V. Koloskov, K. Degtyarev, and O. Strelnikova, "The Deformable and Strength Characteristics of Nanocomposites Improving," *Materials Science Forum*, vol. 1038, 2021, pp. 144–153. doi.org/10.4028/www.scientific.net/MSF.1038.144.
- [16] F. A. Khammas, K. Hussein Suffer, R. Usubamatov, and M.T. Mustafa, "Overview of Vertical Axis Wind Turbine (VAWT) is one of the Wind Energy Application," *Applied Mechanics and Materials*, vol. 793, 2015, pp. 388–392. <https://doi.org/10.4028/www.scientific.net/amm.793.38>