

# The Implementation of Optimized Neural Network to Improve the Accuracy of Flow Measurement by Ultrasonic Flowmeter

<https://doi.org/10.31713/MCIT.2019.20>

Oleksandr Parfeniuk

chair of Automation, Electrotechnical and Computer-Integrated Technologies,  
National University of Water and Environmental Engineering,  
Rivne, Ukraine  
o.i.parfeniuk@nuwm.edu.ua

Olena Poliukhovych

Information Computer Center  
National University of Water and Environmental Engineering,  
Rivne, Ukraine  
o.o.poliukhovych@nuwm.edu.ua

Oleksandr Naumchuk

chair of Automation, Electrotechnical and Computer-Integrated Technologies,  
National University of Water and Environmental Engineering,  
Rivne, Ukraine  
o.m.naumchuk@nuwm.edu.ua

Pawel Mazurek

Faculty of Electrical Engineering and Computer Science,  
Politechnika Lubelska,  
Lublin, Poland  
p.mazurek@pollub.pl

**Abstract**— It is proposed the technology of intellectual measurement of expenses with the use of an artificial neural network for overcoming the constraints caused by nonlinear characteristics of ultrasonic flowmeters. It is presented structural scheme of the proposed technology and structure of the model of the neural network.

**Keywords**— measurement, artificial neural network, ultrasonic flowmeter, flow, liquid, accuracy.

## I. INTRODUCTION

Measurement of flow has been evolving for many years in response to the requirements for the accuracy of measuring the quantitative cost of products. The accuracy of measuring costs is an essential requirement both from a qualitative and an economic point of view. Among contactless methods of measuring the flow, widely used ultrasound. Ultrasonic flowmeters have attracted a lot of attention in recent years, primarily because of their ability to measure the transmission of natural gas. The ultrasonic flowmeter is one of the most interesting types of meters used to measure the cost of pipes.

## II. DESCRIPTION OF TECHNOLOGY

The figure 1 shows the location of the ultrasonic flowmeter on the pipeline. Sending and receiving converters are installed on both sides of the flowmeter or the pipe wall. The sending transducer sends an ultrasound signal at an angle from one side of the pipe and receives a receiving transducer from another. The flowmeter measures the time required for the ultrasonic signal to pass in the forward and reverse direction. When the signal passes along the direction of the flow, it moves faster than the state of the absence of the flow. On the other hand, when the signal moves against the direction of the

flow, it slows down. The difference between the passage time of the two signals is proportional to the flow rate [1].

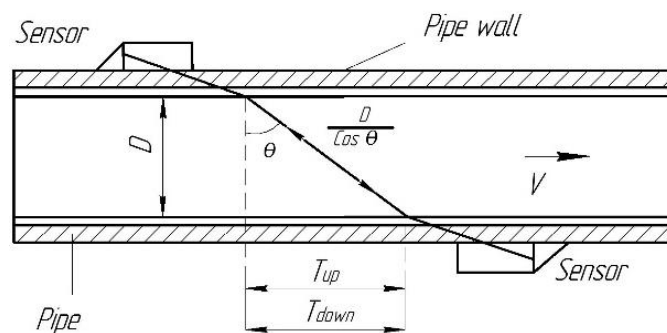

Figure 1. Ultrasonic flowmeter

From the figure 1 we have:

$$T_{up} = \frac{M \cdot \frac{D}{\cos\theta}}{c_0 + V \sin\theta}; \quad T_{down} = \frac{M \cdot \frac{D}{\cos\theta}}{c_0 - V \sin\theta};$$

$$\Delta T = T_{up} - T_{down}; \quad f_{IN} = 1/\Delta T \quad (1)$$

where  $M$  - the quantity of times the ultrasonic signal passes in the forward and reverse direction;  $C_0$  - velocity of ultrasonic signal in static fluid;  $D$  - diameter of the pipe;  $V$  - fluid velocity;  $f_{IN}$  - frequency.

The velocity of the ultrasonic signal depends on the density of the liquid, because:

$$c_0 = \sqrt{k/\rho} \quad (2)$$

where  $k$  – bulk modulus,  $\rho$  – liquid density.

The impact of temperature on the density can be shown:

$$\rho_1 = \left[ \frac{\rho_0}{1 + \alpha(t_1 - t_0)} \right] / \left[ 1 - \frac{(P_{t_1} - P_{t_0})}{E} \right] \quad (3)$$

where  $\rho_1$  – specific liquid density at temperature  $t_1$ ;  $\rho_0$  – specific liquid density at temperature  $t_0$ ;  $P_{t_1}$  – pressure at temperature  $t_1$ ;  $P_{t_0}$  – pressure at temperature  $t_0$ ;  $E$  – elasticity modulus of the liquid;  $\alpha$  – coefficient of temperature of liquid.

### III. DESCRIPTION OF THE DEVELOPED NEURAL NETWORK

However, the nonlinear characteristics of the ultrasonic flowmeter limit the scope of its application. To overcome the constraints caused by the nonlinear characteristics of ultrasonic flowmeters, there are proposed several techniques, although some of them are too labor-intensive and time consuming. Furthermore, the calibration process must be carried out regularly, or the gauge circuit must be replaced/configured whenever the diameter of the pipe or the density of the fluid changes [2]. The problem of the nonlinear response of the characteristics of ultrasonic flowmeters is further exacerbated when there is a change in the temperature of the liquid, since the output signal on the device also depends on the temperature. To overcome the difficulties mentioned above, there is proposed the technology of intellectual measurement of costs. The block diagram of the proposed technology is presented in figure 2:

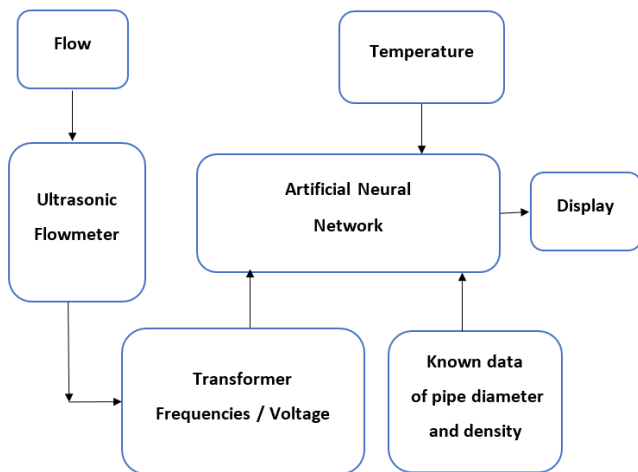

Figure 2. The block diagram of the proposed technology

The artificial neural network optimization (ANN) is achieved by taking into account different algorithms and schemes and by comparing their lowest mean square error (MSE) and regression to one. The optimized ANN is used to obtain a linearity and adaptive to change in diameter of the pipe of the density and temperature of the liquid signal throughout the measurement range. The first step in the case of developing a neural network is to create a database for its training, testing and verification. The output voltage of the data conversion block for a given flow, pipe diameter, density, and temperature of liquid is reserved as the input matrix line.

Various combinations of input flow, pipe diameter, density and fluid temperature, and their corresponding voltages at the output of the data transform block are used to form other lines of the input matrix. The output matrix is a target matrix consisting of data that has a linear relationship with flow and is adapted to changes in pipe diameter, density, and temperature of fluid. The process of finding scales to achieve the desired result is called training. The optimized ANN is located by considering different algorithms with a variation of the number of hidden layers. Four different schemes and algorithms are used to find the optimal SMN, such as: Levenberg-Marquardt algorithm (LMA), Artificial Bee Colony (ABC), Ant Colony Optimization (ACO), Back Propagation (BP) method, trained on an ant colony algorithm. For the first-time studying of ANN is done on only one hidden layer [3]. The number of the mean squared error and regression are indicated. The hidden layer increases to 2 and training is repeated. This process extends to 4 hidden layers. The most optimized ANN is considered to be a network trained by the method of error-propagation with 2 hidden layers to provide the desired accuracy of the result, as shown in figure 3:

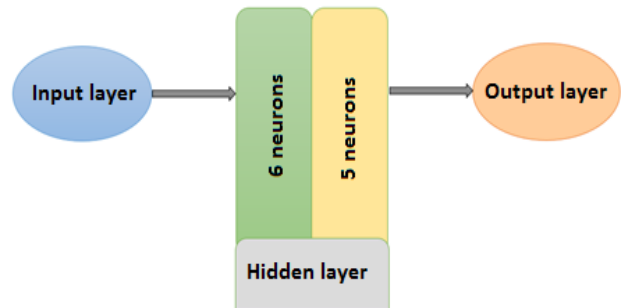

Figure 3. The structure of the neural network model

The optimized ANN is trained and tested with the help of using of simulated data. To the input there can be passed various test data corresponding to different pipe diameters, density and liquid temperature within the respective specified ranges.

### REFERENCES

- [1] Kremljovskij P.P. Rashodomery i schetchiki kolichestva vewestv: Spravochnik: Kn. 2. Pod obw. red. E.A. Shornikova. 5-e izd., pererab. i dop. SPb.: Politehnika, 2004. 412 p.
- [2] J. Yoder, “Many Paths to Successful Flow Measurement”, Flow Control Network, 2006 February.
- [3] Simon Haikin, Neural Networks and Learning Machines (3rd Edition), November 28, 2008. 936 p.